



**BISON PRECAST**

a Forterra brand

# TECHNICAL GUIDANCE NOTE

Building Regulations – Part A - 23 March 2018

This technical note deals with the means of reducing the sensitivity of a building to disproportionate collapse in the event of an accident. The structures are divided into categories depending on the risk factor and the consequences of an accidental failure. These parameters depend on the type of the building, the likelihood of accidents and the number of people that may be affected. These are categorised by consequence class as shown in Table 1.

Table 1 - Building classes (based upon Approved Document A, Table 11)

Class	Building type and occupancy	Action required
1	<ul style="list-style-type: none"> <li>Houses not exceeding 4 storeys</li> <li>Agricultural buildings</li> <li>Buildings into which people rarely go, provided no part of the building is closer to another building, or area where people do go, than a distance of 1.5 times the building height.</li> </ul>	No additional measures
2A	<ul style="list-style-type: none"> <li>5 storey single occupancy houses</li> <li>Hotels not exceeding 4 storeys</li> <li>Flats, apartments and other residential buildings not exceeding 4 storeys</li> <li>Offices not exceeding 4 storeys</li> <li>Industrial buildings not exceeding 3 storeys</li> <li>Retailing premises not exceeding 3 storeys of less than 2000 m<sup>2</sup> floor area in each storey</li> <li>Single storey Educational buildings</li> <li>All buildings not exceeding 2 storeys to which members of the public are admitted and which contain floor areas not exceeding 2000 m<sup>2</sup> at each storey</li> </ul>	Horizontal ties to be provided or effective anchorage of floors to supports
2B	<ul style="list-style-type: none"> <li>Hotels, flats, apartments and other residential buildings greater than 4 storeys but not exceeding 15 storeys</li> <li>Educational buildings greater than 1 storey but not exceeding 15 storeys</li> <li>Retailing premises greater than 3 storeys but not exceeding 15 storeys</li> <li>Hospitals not exceeding 3 storeys</li> <li>Offices greater than 4 storeys but not exceeding 15 storeys</li> <li>All buildings to which members of the public are admitted and which contain floor areas exceeding 2000 m<sup>2</sup> but less than 5000 m<sup>2</sup> at each storey</li> <li>Car parking not exceeding 6 storeys</li> </ul>	Horizontal ties to be provided together with either vertical ties or allowance made for the notional removal of support
3	<ul style="list-style-type: none"> <li>All buildings defined above as Class 2A and 2B that exceed the limits on area and/or number of storeys</li> <li>All buildings, containing hazardous substances and/or processes</li> <li>Grandstands accommodating more than 5000 spectators</li> </ul>	Specific consideration to take account of the likely hazards

OUR PEOPLE. OUR PASSION. OUR PRODUCTS

The components you need for a more successful project.

Bison Precast - Tetron Point - William Nadin Way - Swadlincote - Derbyshire - DE11 0BB

01283 817 500 concrete@bison.co.uk bison.co.uk



**BISON PRECAST**

a Forterra brand

# TECHNICAL GUIDANCE NOTE

Building Regulations – Part A - 23 March 2018

## Design aspects

The specific requirements relating to ties in precast concrete structures are given in BS EN 1992-1-1. These are satisfied either by using individual continuous ties provided explicitly for this purpose in in-situ concrete strips, or using ties partly in the in-situ and partly in the precast components. The structural model is as follows. In the event of the complete loss of a supporting column or beam at a floor level, the floor at this level and the level above must resist total collapse.

- Floor ties: Ties connecting floors over an internal support
- Perimeter floor ties: Tie connecting floors to a perimeter support
- Internal ties: Ties over an intermediate support perpendicular to the span of the floor
- Peripheral ties: Ties over a peripheral support
- Vertical ties: Ties connecting vertical walls or columns to provide continuity

## Definitions of floor ties

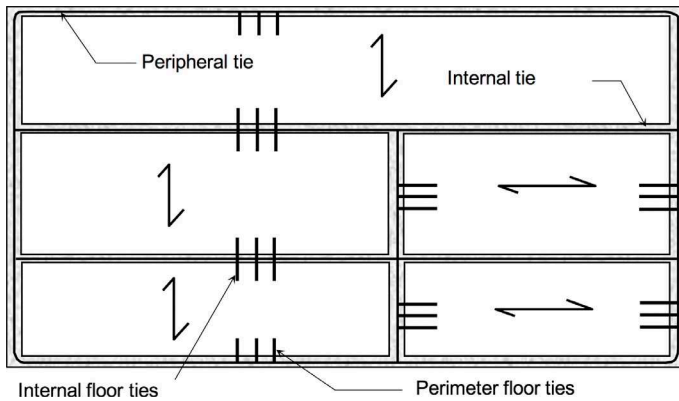

## Plan view (Hollow core floor)

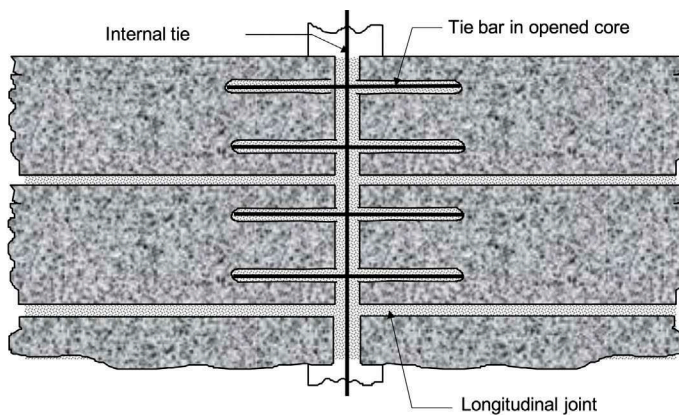



**BISON PRECAST**

a Forterra brand

# TECHNICAL GUIDANCE NOTE

Building Regulations – Part A - 23 March 2018

Typical details for hollow core floors on masonry

Class 1 and 2A buildings

- Effective anchorage is provided where a hollow core slab spans onto a wall and has a bearing of one half of the width of the wall or at least 90 mm.
- Where a precast hollow core slab spans parallel to a wall and abuts a wall, straps at 1.25 m centres would be required.
- Where a precast hollow core slab spans parallel to a wall and is built into the wall, this would be deemed to be 'effective anchorage' with no requirement for straps providing:
  - a) The slab is fully and effectively built into the wall during construction with a wet mortar bed above and below taking due account of any pre-camber in the units
  - b) The slab adjacent to the wall should be at least 750 mm wide
  - c) The units have a bearing of one half of the width of the wall or at least 90mm.
- The bearing of slabs should be in accordance with BS EN 1992-1-1.
- The design of all straps is the responsibility of the Building Designer and should be in accordance with BS EN 1996.
- All diagrams are not to scale and are indicative only.

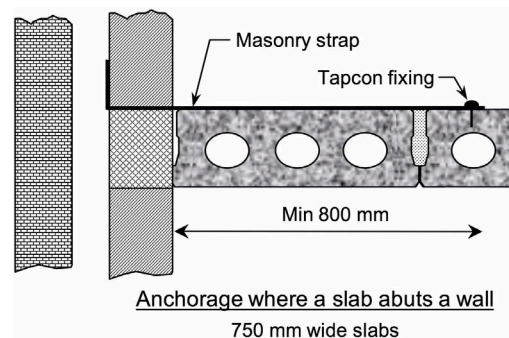
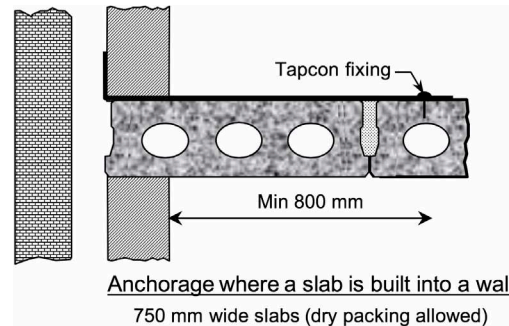
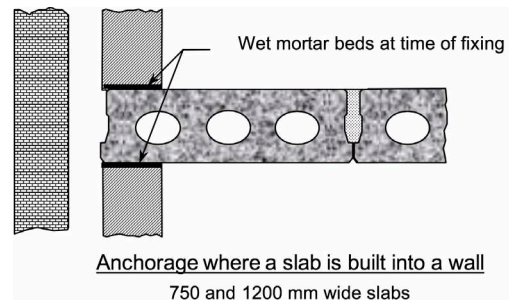
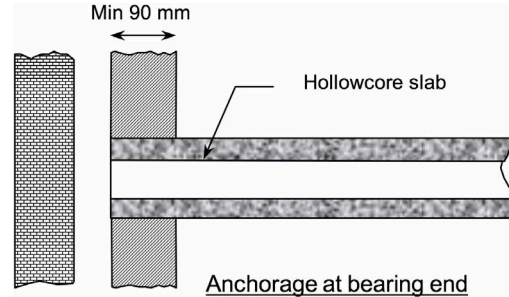



**BISON PRECAST**

a Forterra brand

# TECHNICAL GUIDANCE NOTE

Building Regulations – Part A - 23 March 2018

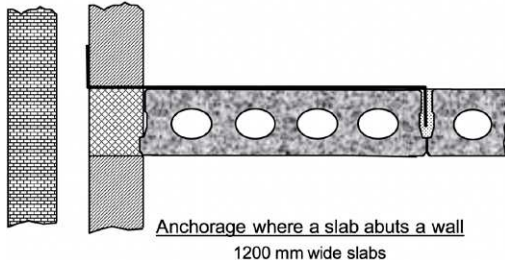

Anchorage where a slab abuts a wall  
1200 mm wide slabs

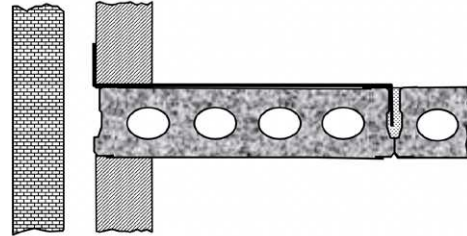

Anchorage where a slab is built into a wall  
1200 mm wide slabs (dry packing allowed)

## Class 3 and 2B buildings - Typical details for hollow core floors with concrete topping

- Where a structural concrete topping is used, opening of cores for tying purposes may not be required. The reinforcement in the topping is usually sufficient to comply with the tying requirements but the specific design must be checked by the Building Designer.
- The minimum bearing of slabs should be in accordance with BS EN 1992-1-1
- The design of all tying reinforcement is the responsibility of the Building Designer
- Where longitudinal tying reinforcement is provided no additional reinforcement is required at the slab edges
- All diagrams are not to scale and are indicative only

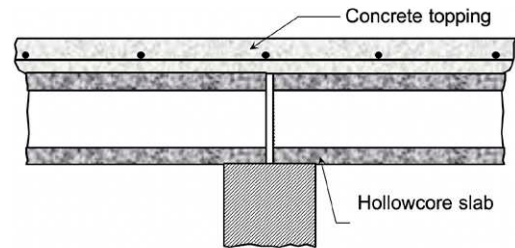

Internal floor ties within the concrete topping

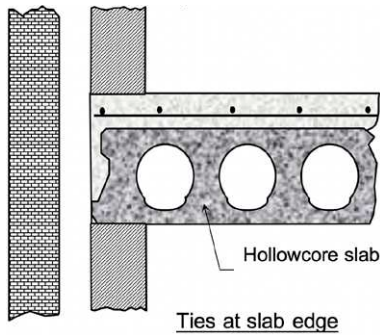

Ties at slab edge

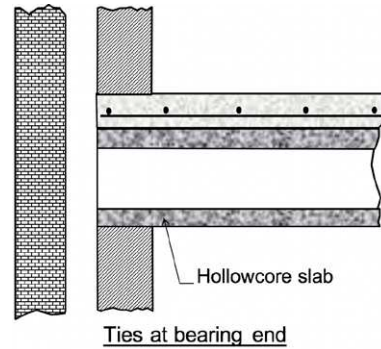

Ties at bearing end

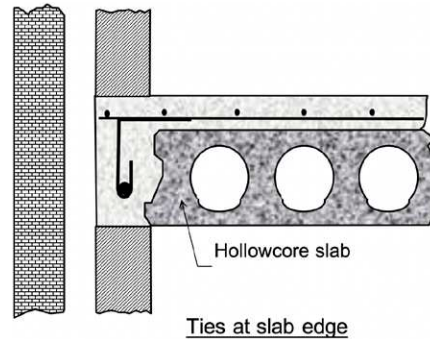

Ties at slab edge



**BISON PRECAST**

a Forterra brand

# TECHNICAL GUIDANCE NOTE

Building Regulations – Part A - 23 March 2018

Class 3 and 2B buildings - Typical details for hollow core floors without concrete topping

- The minimum bearing of slabs should be in accordance with BS EN 1992-1-1
- The recommended maximum aggregate size in the in-situ concrete is 10 mm
- The recommended minimum grade of the in-situ concrete is C30
- Opening of edge cores or two adjacent cores is not permitted
- The recommended maximum length of an open core is 600 mm
- Tying reinforcement may be placed in the joints provided there is sufficient gap
- The design of all tying reinforcement is the responsibility of the Building Designer
- Where longitudinal tying reinforcement is provided no additional reinforcement is required at the slab edges
- All diagrams are not to scale and are indicative only

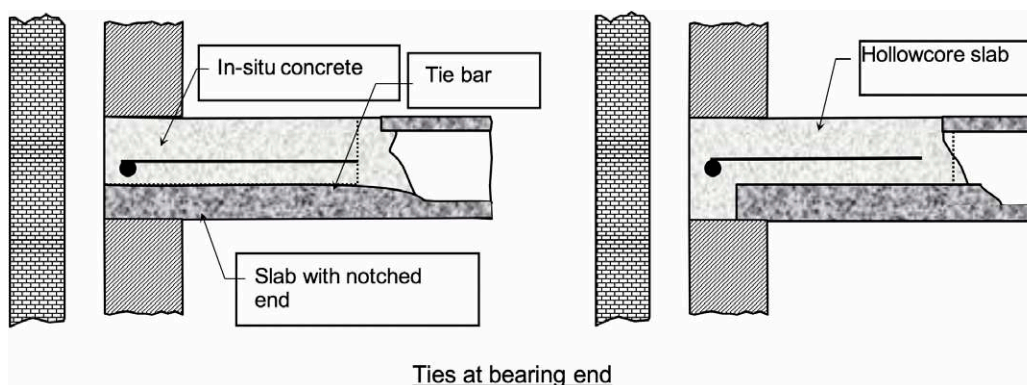
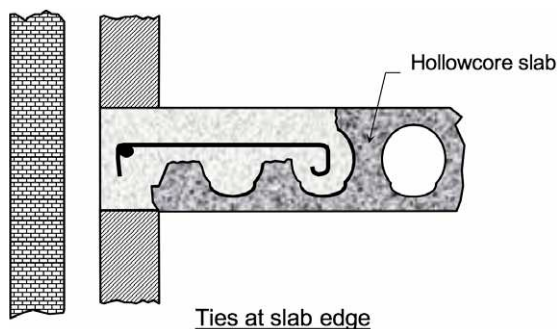
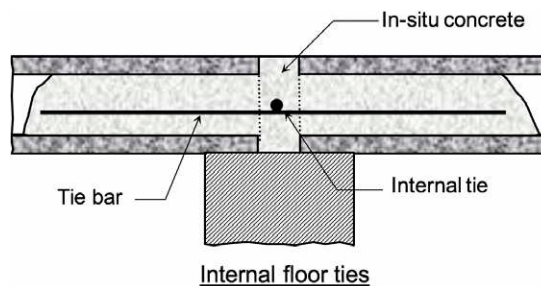



**BISON PRECAST**

a Forterra brand

# TECHNICAL GUIDANCE NOTE

Building Regulations – Part A - 23 March 2018

Typical details for hollow core floors on steel frame

Class 1 and 2A buildings

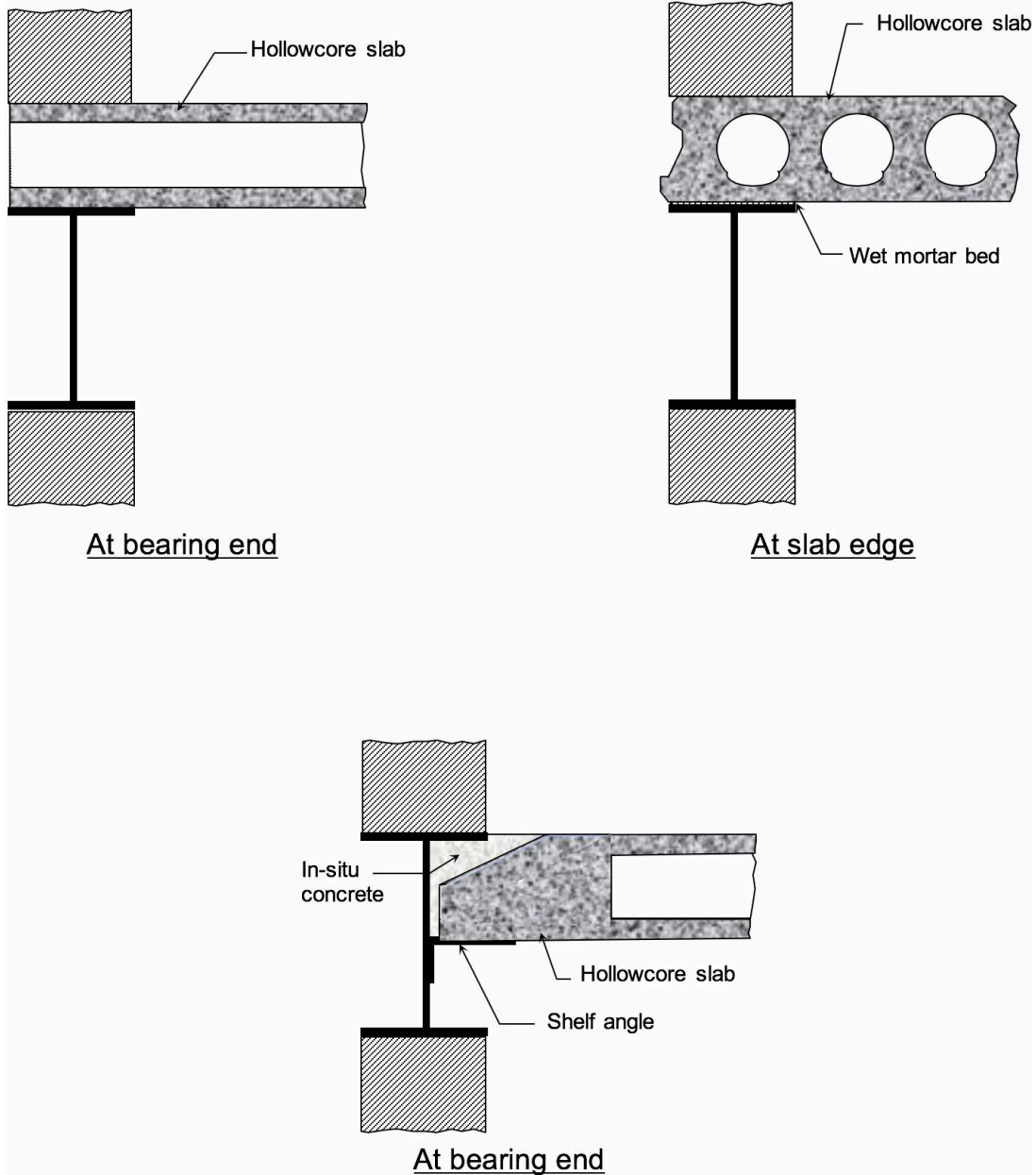



**BISON PRECAST**

a Forterra brand

# TECHNICAL GUIDANCE NOTE

Building Regulations – Part A - 23 March 2018

Class 3 and 2B buildings

